



NTIP2082M Three-Axis Vibration Transducer with Built-In Electronics



Parameter	Unit	NTIP2082M
Axial sensitivity ($\pm 10\%$).....	mV/g ^{*1}	100
Relative transverse sensitivity.....	%	< 5
Amplitude range.....	g ^{*1}	± 50
Max. shock limit (peak value).....	g ^{*1}	± 100
Operating temperature range.....	° C	- 40...+ 125
Frequency range (ripple ± 1 dB).....	Hz	0.5...10 000
Self-resonant frequency in attached condition.....	kHz	> 30
Noise level, RMS (1 Hz ... 10 kHz).....	g ^{*1}	< 0.000 3
Output resistance.....	Ohm	< 500
Voltage power.....	V	+ (18...30)
Current power.....	mA	2...20
Constant output voltage level.....	V	10...13
Turn-on time.....	s	4
Design.....	-	Shear
Bottom insulation.....	-	no
Housing material.....	-	Stainless steel
Weight (without connector and cable).....	gram	13

General view

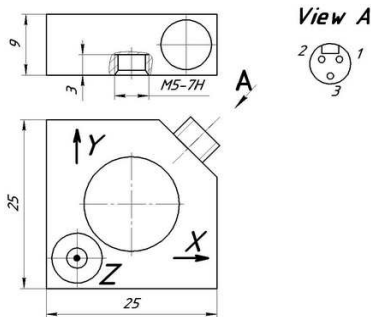

Electrical circuit

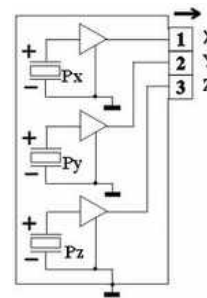

The circuit of connection to a data-acquisition equipment

